

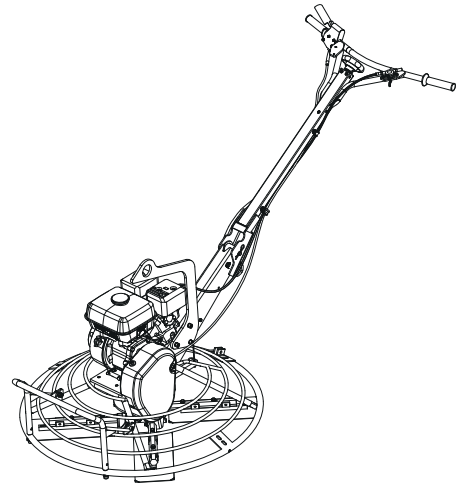

**Chicago
Pneumatic**

Safety and operating instructions

**Trowel
STG 244, 375, 479**



Contents

Introduction	5
About the Safety and operating instructions	5
Safety instructions	5
Safety signal words	5
Personal precautions and qualifications	5
Personal protective equipment	5
Drugs, alcohol or medication	5
Operating, precautions	6
Transport, precautions	9
Maintenance, precautions	9
Storage, precautions	9
Overview	10
Design and function	10
Main parts	10
Labels	10
Data plate	10
Instruction manual label	11
Lifting point label	11
Use ear protectors label	11
Blade angle label	11
Throttle control label	11
Tilted position label	11
Cutting hazard label	11
Safety label	11
Transport	11
Lifting the machine	11
Installation	12
Fuel	12
Filling	12
Fitting and removing the trowel blades	13
Operation	13
Operating near edges	14
Start and stop	14
Before starting	14
Starting the engine	14
Stopping the engine	15
Operating	16
Floating	16
Finishing	16
Manoeuvring the trowel	16
Adjusting the blade angle	17
Twist pitch	17
Quick pitch	17
When taking a break	17
Maintenance	18
Every 10 hours of operation (daily)	18
Checking the engine	18

After the first 20 hours of operation	19
Changing the engine oil	19
Every 200 hours of operation (or monthly)	19
Checking the V-belt	19
Checking spark plug	20
Every 500 hours of operation (or yearly)	20
Cleaning the fuel tank	20
Inspection and adjustment of engine	20
Cleaning the blade shafts - STG 244	20
Cleaning the blade shafts - STG 375/479	21
Cleaning the pressure plate	21
Repair	21
Clutch wire replacement	21
Storage	23
Disposal	23
Troubleshooting	24
Technical data	25
Machine data - STG 244	25
Weights and dimensions for options - STG 244	25
Machine data - STG 375	26
Weights and dimensions for options - STG 375	26
Machine data - STG 479	27
Weights and dimensions for options - STG 479	27
Noise and vibration declaration statement	28
Noise and vibration data	28
Uncertainties, sound value	28
Dimensions	29
EC Declaration of Conformity	32
EC Declaration of Conformity (EC Directive 2006/42/EC)	32

Introduction

Thank you for choosing Chicago Pneumatic brand products. For over a century, the Chicago Pneumatic brand has represented performance and innovation in the pneumatic tool industry.

Today the brand is found around the world on a range of pneumatic and hydraulic tools that includes breakers, rock drills, chipping hammers, clay-diggers, picks and busters, scabblers, pumps and a whole lot more.

The Chicago Pneumatic brand is associated with powerful and reliable products that are easy to maintain and that give good value for the money.

For more information please visit www.cp.com

Construction Tools EOOD

7000 Rousse

Bulgaria

About the Safety and operating instructions

The aim of the instructions is to provide you with knowledge of how to use the machines in an efficient, safe way. The instructions also give you advice and tell you how to perform regular maintenance on the machines.

Before using the machines for the first time you must read these instructions carefully and understand all of them.

Safety instructions

To reduce the risk of serious injury or death to yourself or others, read and understand the Safety and operating instruction before installing, operating, repairing, maintaining, or changing accessories on the machine.

Post this Safety and operating instruction at work locations, provide copies to employees, and make sure that everyone reads the Safety and operating instruction before operating or servicing the machine. For professional use only.

In addition, the operator or the operator's employer must assess the specific risks that may be present as a result of each use of the machine.

Additional instructions for the engine can be found in the manufacturer's engine manual.

Save all warnings and instructions for future reference.

Safety signal words

The safety signal words Danger, Warning and Caution have the following meanings:

DANGER	Indicates a hazardous situation which, if not avoided, will result in death or serious injury.
WARNING	Indicates a hazardous situation which, if not avoided, could result in death or serious injury.
CAUTION	Indicates a hazardous situation which, if not avoided, could result in minor or moderate injury.

Personal precautions and qualifications

Only qualified and trained persons may operate or maintain the machine. They must be physically able to handle the bulk, weight, and power of the machine. Always use your common sense and good judgement.

Personal protective equipment

Always use approved protective equipment. Operators and all other persons in the working area must wear protective equipment, including at a minimum:

- Protective helmet
- Hearing protection
- Impact resistant eye protection with side protection
- Respiratory protection when appropriate
- Protective gloves
- Proper protective boots
- Appropriate work overall or similar clothing (not loose-fitting) that covers your arms and legs.

Drugs, alcohol or medication

▲ **WARNING** Drugs, alcohol or medication

Drugs, alcohol or medication may impair your judgment and powers of concentration. Poor reactions and incorrect assessments can lead to severe accidents or death.

- ▶ Never use the machine when you are tired or under the influence of drugs, alcohol or medication.

- ▶ No person who is under the influence of drugs, alcohol or medication may operate the machine.

Operating, precautions

⚠ **DANGER Explosion hazard**

If a warm machine or exhaust pipe comes into contact with explosives, an explosion could occur. During operating with certain materials, sparks and ignition can occur. Explosions will lead to severe injuries or death.

- ▶ Never operate the machine in any explosive environment.
- ▶ Never use the machine near flammable materials, fumes or dust.
- ▶ Make sure that there are no undetected sources of gas or explosives.
- ▶ Avoid contact with the warm exhaust pipe or the bottom of the machine.

⚠ **DANGER Fire hazard**

If a fire starts in the machine, it can cause injury.

- ▶ If possible use an AB(E)-class powder extinguisher, otherwise use a B(E)-type carbon dioxide fire extinguisher.

⚠ **DANGER Fuel hazard**

The fuel is flammable and fuel fumes can explode when ignited, causing serious injury or death.

- ▶ Protect your skin from contact with the fuel. If fuel has penetrated the skin, consult a qualified health professional.
- ▶ Never remove the filler cap, or fill the fuel tank when the machine is hot.
- ▶ Fill the fuel tank outdoors or in a clean and well ventilated place, free from sparks and open flames. Fill the fuel tank at least ten meters (30 feet) from the place where the machine is to be used.
- ▶ Release the filler cap slowly to let pressure escape.
- ▶ Never overfill the fuel tank.
- ▶ Make sure the filler cap is screwed on when the machine is used.
- ▶ Avoid spilling fuel on the machine, wipe off any spilled fuel.
- ▶ Check regularly for fuel leaks. Never use the machine if it is leaking fuel.

- ▶ Never use the machine in the proximity of material that can generate sparks. Remove all hot or spark-generating devices before starting the machine.
- ▶ Never smoke when filling the fuel tank or when working with the machine or servicing it.
- ▶ Only store fuel in a container that is specially constructed and approved for the purpose.
- ▶ Consumed fuel and oil containers must be taken care of and returned to the retailer.
- ▶ Never use your fingers to check for fluid leaks.

⚠ **WARNING Unexpected movement**

The machine is exposed to heavy strains during operation. If the machine breaks or gets stuck, there may be sudden and unexpected movement that can cause injuries.

- ▶ Always inspect the machine prior to use. Never use the machine if you suspect that it is damaged.
- ▶ Make sure that the handle is clean and free of grease and oil.
- ▶ Keep your feet away from the machine.
- ▶ Never sit on the machine.
- ▶ Never strike or abuse the machine.
- ▶ Pay attention and look at what you are doing.

⚠ **WARNING Dust and fume hazard**

Dusts and/or fumes generated or dispersed when using the machine may cause serious and permanent respiratory disease, illness, or other bodily injury (for example, silicosis or other irreversible lung disease that can be fatal, cancer, birth defects, and/or skin inflammation).

Some dusts and fumes created by compaction work contain substances known to the State of California and other authorities to cause respiratory disease, cancer, birth defects, or other reproductive harm. Some examples of such substances are:

- Crystalline silica, cement, and other masonry products.
- Arsenic and chromium from chemically-treated rubber.
- Lead from lead-based paints.

Dust and fumes in the air can be invisible to the naked eye, so do not rely on eye sight to determine if there is dust or fumes in the air.

To reduce the risk of exposure to dust and fumes, do all of the following:

- ▶ Perform site-specific risk assessment. The risk assessment must include dust and fumes

created by the use of the machine and the potential for disturbing existing dust.

- ▶ Use proper engineering controls to minimize the amount of dust and fumes in the air and to minimize build-up on equipment, surfaces, clothing, and body parts. Examples of controls include: exhaust ventilation and dust collection systems, water sprays, and wet drilling. Control dusts and fumes at the source where possible. Make sure that controls are properly installed, maintained and correctly used.
- ▶ Wear, maintain and correctly use respiratory protection as instructed by your employer and as required by occupational health and safety regulations. The respiratory protection must be effective for the type of substance at issue (and if applicable, approved by relevant governmental authority).
- ▶ Work in a well ventilated area.
- ▶ If the machine has an exhaust, direct the exhaust so as to reduce disturbance of dust in a dust filled environment.
- ▶ Operate and maintain the machine as recommended in the operating and safety instructions
- ▶ Wear washable or disposable protective clothes at the worksite, and shower and change into clean clothes before leaving the worksite to reduce exposure of dust and fumes to yourself, other persons, cars, homes, and other areas.
- ▶ Avoid eating, drinking, and using tobacco products in areas where there is dust or fumes.
- ▶ Wash your hands and face thoroughly as soon as possible upon leaving the exposure area, and always before eating, drinking, using tobacco products, or making contact with other persons.
- ▶ Comply with all applicable laws and regulations, including occupational health and safety regulations.
- ▶ Participate in air monitoring, medical examination programs, and health and safety training programs provided by your employer or trade organizations and in accordance with occupational health and safety regulations and recommendations. Consult with physicians experienced in relevant occupational medicine.
- ▶ Work with your employer and trade organization to reduce dust and fume exposure at the worksite and to reduce the risks. Effective health and safety programs, policies and procedures for protecting workers and others against harmful exposure to dust and fumes must be established and implemented based

on advice from health and safety experts. Consult with experts.

⚠ **DANGER Exhaust gas hazard**

The exhaust gas from the machine's combustion engine contains carbon monoxide which is poisonous, and chemicals known to the State of California and other authorities to cause cancer, birth defects, or other reproductive harm. Inhalation of exhaust fumes can cause serious injury, illness, or death.

- ▶ Never inhale exhaust fumes.
- ▶ Ensure good ventilation (extraction of air by fan if necessary).

⚠ **WARNING Projectiles**

Failure of the work piece, of accessories, or even of the machine itself may generate high velocity projectiles. During operating, splinters or other particles from the compacted material may become projectiles and cause personal injury by striking the operator or other persons. To reduce this risk:

- ▶ Use approved personal protective equipment and safety helmet, including impact resistant eye protection with side protection.
- ▶ Make sure that no unauthorised persons trespass into the working zone.
- ▶ Keep the workplace free from foreign objects.

⚠ **WARNING Rotating blades hazards**

There is a risk of hands and feet getting caught by the rotating blades when the machine is running. This can cause personal injury.

- ▶ Never place your hands or feet inside the protection ring when the machine is running.

⚠ **WARNING Motion hazards**

When using the machine to perform work-related activities, you may experience discomfort in the hands, arms, shoulders, neck, or other parts of the body.

- ▶ Adopt a comfortable posture while maintaining secure footing and avoiding awkward off-balanced postures.
- ▶ Changing posture during extended tasks may help avoid discomfort and fatigue.
- ▶ In case of persistent or recurring symptoms, consult a qualified health professional.

⚠ WARNING Vibration hazards

Normal and proper use of the machine exposes the operator to vibration. Regular and frequent exposure to vibration may cause, contribute to, or aggravate injury or disorders to the operator's fingers, hands, wrists, arms, shoulders and/or nerves and blood supply or other body parts, including debilitating and/or permanent injuries or disorders that may develop gradually over periods of weeks, months, or years. Such injuries or disorders may include damage to the blood circulatory system, damage to the nervous system, damage to joints, and possibly damage to other body structures.

If numbness, persistent recurring discomfort, burning sensation, stiffness, throbbing, tingling, pain, clumsiness, weakened grip, whitening of the skin, or other symptoms occur at any time, when operating the machine or when not operating the machine, stop operating the machine, tell your employer and seek medical attention. Continued use of the machine after the occurrence of any such symptom may increase the risk of symptoms becoming more severe and/or permanent.

Operate and maintain the machine as recommended in these instructions, to prevent an unnecessary increase in vibration.

The following may help to reduce exposure to vibration for the operator:

- ▶ If the machine has vibration absorbing handles, keep them in a central position, avoid pressing the handles into the end stops.
- ▶ When the percussion mechanism is activated, the only body contact with the machine you must have are your hands on the handle or handles. Avoid any other contact, for example supporting any part of the body against the machine or leaning onto the machine trying to increase the feed force.
- ▶ Make sure that the machine is well-maintained and not worn out.
- ▶ Immediately stop working if the machine suddenly starts to vibrate strongly. Before resuming the work, find and remove the cause of the increased vibrations.
- ▶ Participate in health surveillance or monitoring, medical exams and training programs offered by your employer and when required by law.
- ▶ When working in cold conditions wear warm clothing and keep hands warm and dry.

See the "Noise and vibration declaration statement" for the machine, including the declared vibration values. This information can be found at the end of these Safety and operating instructions.

⚠ WARNING Trapping hazard

There is a risk of neck ware, hair, gloves, and clothes getting dragged into or caught by rotating machine parts. This may cause choking, scalping, lacerations, or death. To reduce the risk:

- ▶ Never grab or touch a rotating machine part.
- ▶ Avoid wearing clothing, neck ware or gloves that may get caught.
- ▶ Cover long hair with a hair net.

⚠ DANGER Electrical hazard

The machine is not electrically insulated. If the machine comes into contact with electricity, serious injuries or death may result.

- ▶ Never operate the machine near any electric wire or other source of electricity.
- ▶ Make sure that there are no concealed wires or other sources of electricity in the working area.

⚠ WARNING Concealed object hazard

During operating, concealed wires and pipes constitute a danger that can result in serious injury.

- ▶ Check the composition of the material before operating.
- ▶ Watch out for concealed cables and pipes for example electricity, telephone, water, gas, and sewage lines.
- ▶ If the machine seems to have hit a concealed object, switch off the machine immediately.
- ▶ Make sure that there is no danger before continuing.

⚠ WARNING Involuntary start

Involuntary start of the machine may cause injury.

- ▶ Keep your hands away from the start and stop device until you are ready to start the machine.
- ▶ Learn how the machine is switched off in the event of an emergency.

⚠ WARNING Noise hazard

High noise levels can cause permanent and disabling hearing loss and other problems such as tinnitus (ringing, buzzing, whistling, or humming in the ears). To reduce risks and prevent an unnecessary increase in noise levels:

- ▶ Risk assessment of these hazards and implementation of appropriate controls is essential.
- ▶ Operate and maintain the machine as recommended in these instructions.

- ▶ If the machine has a silencer, check that it is in place and in good working condition.
- ▶ Always use hearing protection.

Transport, precautions

⚠ WARNING Loading and unloading hazard

When the machine is lifted by a crane and similar appliance, this can lead to injury.

- ▶ Use marked lifting points.
- ▶ Make sure that all lifting devices are dimensioned for the weight of the machine.
- ▶ Never remain under or in the immediate vicinity of the machine.

Maintenance, precautions

⚠ WARNING Unexpected start hazard

During maintenance or when changing blades on the machine, there is a risk that the engine backfires or that the machine unexpectedly starts. This applies especially when the engine is hot and if the switch is in position ON. This can result in serious personal injury.

- ▶ Always let the engine cool down.
- ▶ Always turn the switch to position OFF.
- ▶ Always take the cap off the spark plug.

⚠ WARNING Machine modification

Any machine modification may result in bodily injuries to yourself or others.

- ▶ Never modify the machine. Modified machines are not covered by warranty or product liability.
- ▶ Always use original parts, working tools and accessories.
- ▶ Change damaged parts immediately.
- ▶ Replace worn components in good time.

⚠ CAUTION High temperature

The machine's engine exhaust pipe, and bottom become hot during operation. Touching them can lead to burns.

- ▶ Never touch a hot machine.
- ▶ Never touch the bottom of the machine when its hot.

- ▶ Wait until the engine, exhaust pipe, and bottom of the machine have cooled down before carrying out maintenance work.

Storage, precautions

- ◆ Keep the machine in a safe place, out of the reach of children and locked up.

Overview

To reduce the risk of serious injury or death to yourself or others, read the Safety instructions section found on the previous pages of this manual before operating the machine.

Design and function

STG 244, STG 375 and STG 479 are intended to be used for finishing newly cast concrete surfaces. The concrete surface can be power floated with a floating disc or floating blades and power trowelled with trowelling blades of steel. No other use is permitted. The surface achieved will be even, dense and have a high finish.

The trowel series must only be used in well-ventilated areas, as is the case for all combustion engine machines.

To choose the correct parts, kits and accessories, see the spare parts list.

Main parts

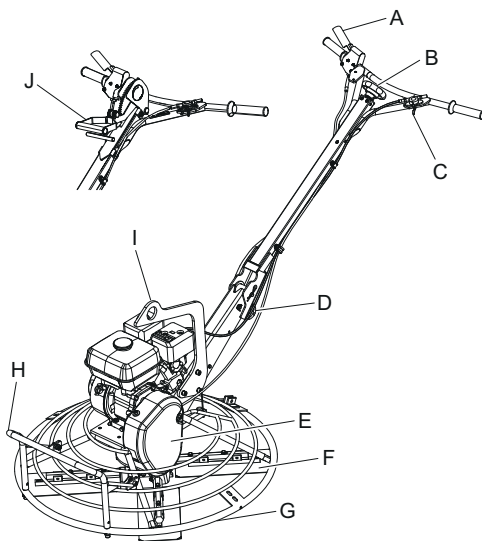

- A. Clutch handle
- B. Blade adjustment (twist pitch model)
- C. Throttle control
- D. Handle folding lock
- E. Protective cover
- F. Blade
- G. Protection ring
- H. Support frame / Lifting device
- I. Lifting eye
- J. Blade adjustment (quick pitch model)

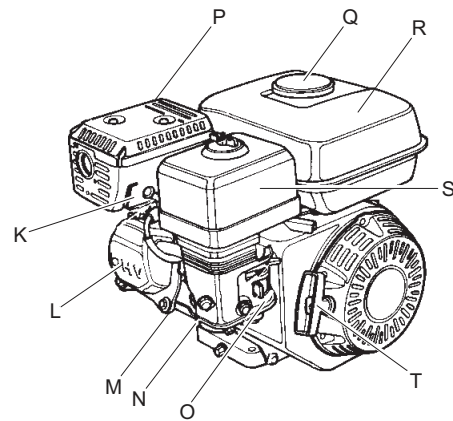

- K. Spark plug
- L. Engine valves
- M. Cooling flanges
- N. Engine oil/dipstick
- O. Carburettor
- P. Silencer
- Q. Fuel filler cap
- R. Fuel tank
- S. Air filter
- T. Recoil starter

Labels

The machine is fitted with labels containing important information about personal safety and machine maintenance. The labels must be in such condition that they are easy to read. New labels can be ordered from the spare parts list.

Data plate

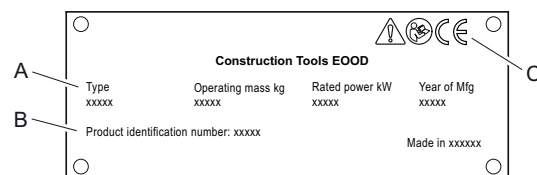

- A. Machine type
- B. Product Identification Number
- C. The CE symbol means that the machine is EC-approved. See the EC Declaration of Conformity which is delivered with the machine for more information.

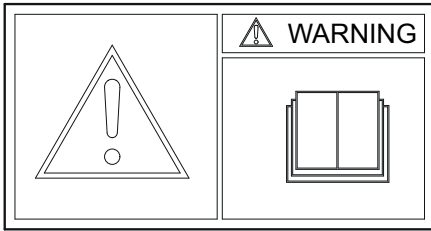
Instruction manual label

The operator must read the safety, operation and maintenance instructions before operating the machine.

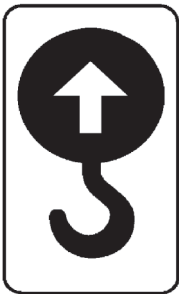
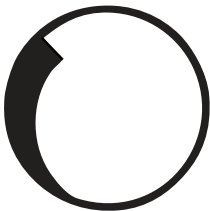
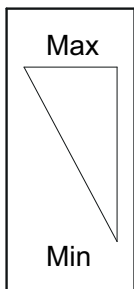
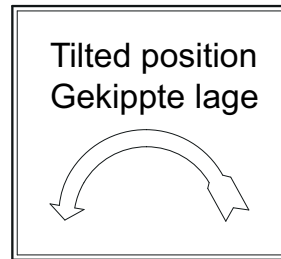
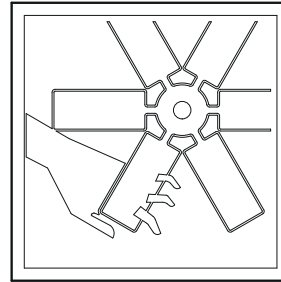
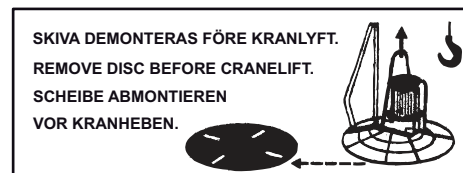
Lifting point label**Use ear protectors label****Blade angle label****Throttle control label****Tilted position label****Cutting hazard label****Safety label**

- ◆ Remove disc before crane lift.

NOTICE Whether you transport the machine by hand or by lifting eye, always remove the disc first.

Transport**Lifting the machine****▲ WARNING Lifting hazard**

Never lift the machine without checking if it is intact. A damaged machine can fall apart, which can result in serious injury.

- ▶ Check that all equipment is dimensioned in accordance with applicable regulations.
- ▶ Never walk or stand under a lifted machine.
- ▶ Always use the lifting eye for machine lift.
- ▶ Always remove the smoothing disc before lifting the machine.
- ▶ Never use the protection ring as a lifting device.
- ▶ Never stand near the machine when lifting and transporting.

- ▶ Check the machine's data plate for weight information.

Lifting the machine

1. Always use the machine's lifting eye (A) to lift the machine.

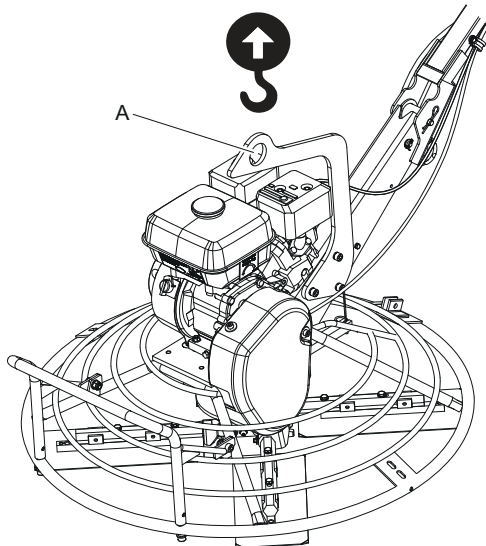

2. Lifting equipment must be dimensioned in order to fulfil all regulations.

Lifting by hand

1. When lifting by hand use the operator handle (B) and the lift handle/support bar (C) in the front of the trowel.

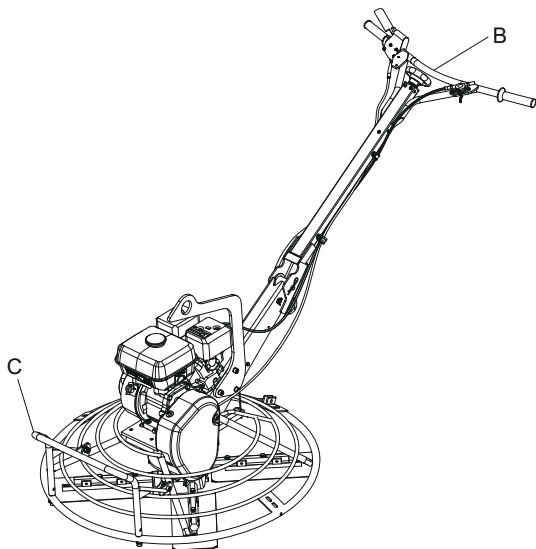

▲ WARNING Transport

During transportation the machine can overturn and cause serious injury.

- ▶ Always strap the machine down.
- ▶ Keep your feet away from the machine.

Transporting the machine

1. Secure the machine for all transportation.

2. Fold the upper handle to its lowest position during transport.

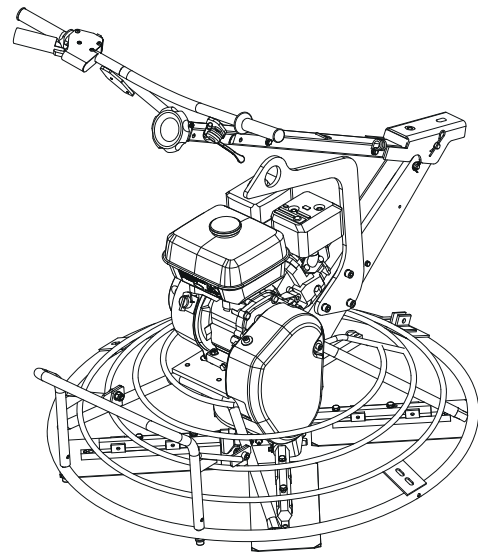

Installation

Fuel

Filling

▲ WARNING Fuel hazard

The fuel is extremely flammable and fuel fumes can explode when ignited, causing serious injury or death.

- ▶ Protect your skin from contact with the fuel.
- ▶ Never remove the filler cap or fill the fuel tank when the machine is hot.
- ▶ Never smoke when filling the fuel tank or when working with the machine or servicing it.
- ▶ Avoid spilling fuel and wipe off any fuel spilled on the machine.

Filling procedure

1. Stop the engine and let it cool down before filling the tank.
2. Release the filler cap slowly to let any pressure escape.
3. Fill the fuel tank to the lower edge of the filler pipe.

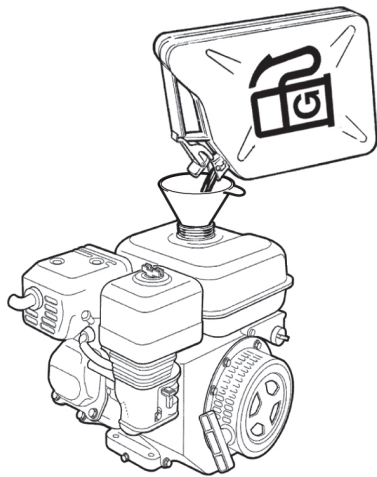

4. Never overfill the tank. Due to the movement of the fuel within the tank, it is possible to have fuel at a higher level than the tank cap, which can lead to a spillage of fuel if the tank cap is opened. This can be avoided by only opening the tank cap when the machine is on level ground and the tank cap is at the fuel tank's highest point.

Fitting and removing the trowel blades

- ◆ To prevent an accidental start: Turn the engine switch to position OFF and let the engine cool down.
- ◆ Lubricate the blade shafts with recommended grease using the grease nipple on the hub, see chapter "Machine data".

Whenever fitting or removing the trowel blades the following instructions must be observed:

STG 244

1. Lean the trowel forwards so it rests on the support frame.
2. Loosen the screw (A) and remove the spider assembly.
3. Loosen the screws (B) and change the blades (C).

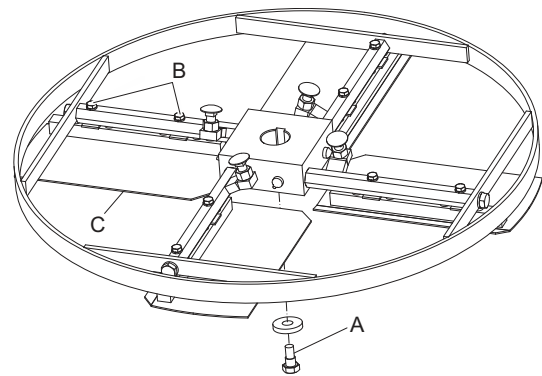

STG 375/479

1. Lean the trowel forwards so it rests on the support frame.
2. Loosen the screw (A) and remove the spider assembly.
3. Loosen the screws (B) and change the blades (C).

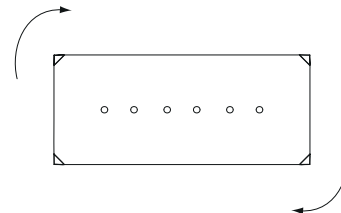
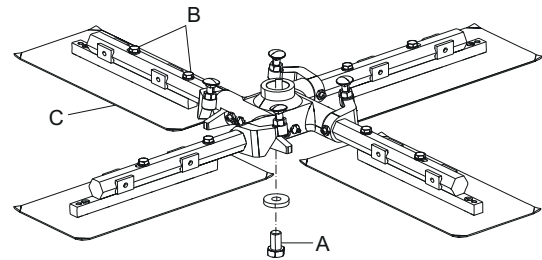

NOTICE On the 375/479 models the blades are reversible for double life.

Operation

▲ **WARNING Engine running hazard**

Vibrations from the engine can cause material changes, this can cause the machine to move and cause injuries.

- ▶ Never leave the machine with the engine running.
- ▶ Ensure that only authorized personnel operate the machine.

NOTICE When operating the machine, follow the instructions in the manual; never sit or stand on the machine when it is working.

Operating near edges

⚠ **WARNING** Overturning hazard

When operating along edges, at least two thirds of the machine must be on a surface with full bearing strength, otherwise the machine can tip over.

- ▶ Switch off the machine and lift it back on a surface with full bearing strength.

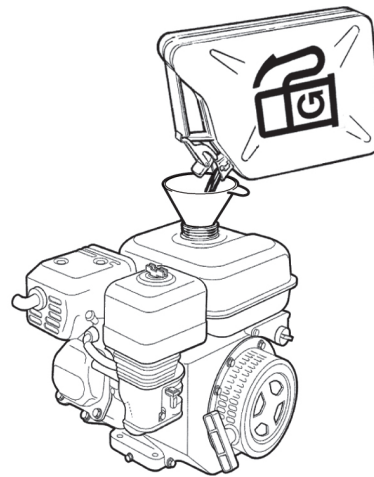
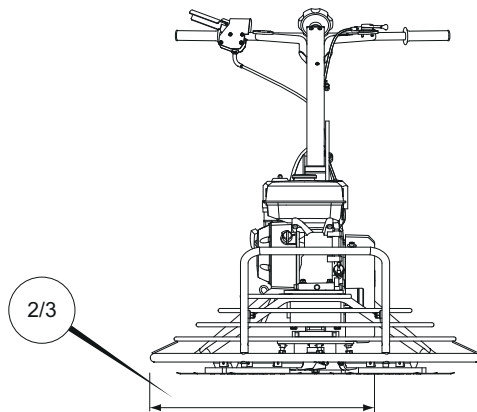

- ◆ Check that all the controls are working.
- ◆ Make sure that there is no oil leakage, and that all bolted joints are tightened.
- ◆ After the engine is started, leave the speed control in the idling position for a few minutes to warm up the engine without loading it.

Start and stop

Before starting

Follow the general safety precautions supplied with the machine at delivery. We recommend to study the engine manual supplied with the machine. Check that maintenance routines have been carried out.

- ◆ Check the engine oil level on the dipstick.

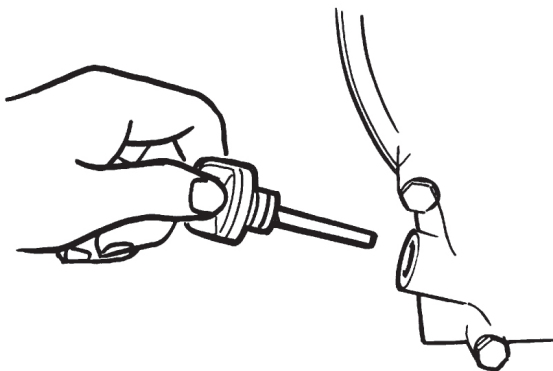

- ◆ Fill the fuel tank with fuel.

Starting the engine

1. Open the fuel cock (A).

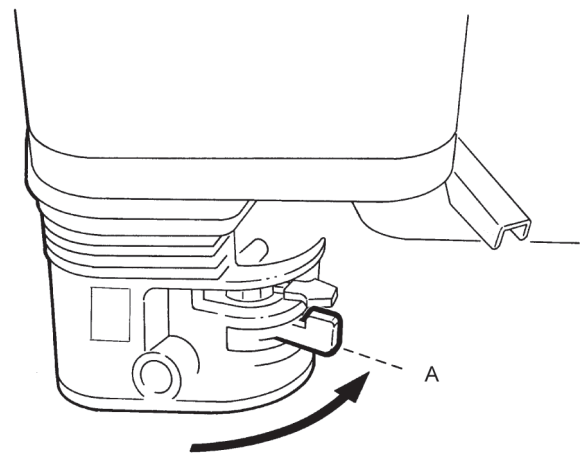

2. Set the throttle control (B) for idle speed. Do not use higher r.p.m. during the start process.

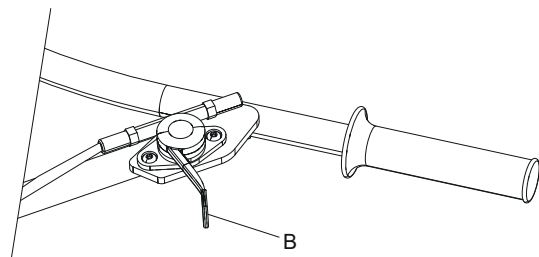

3. Close the choke (C) if the engine is cold. If the engine is warm or the ambient temperature is high, close the choke halfway or leave it open.

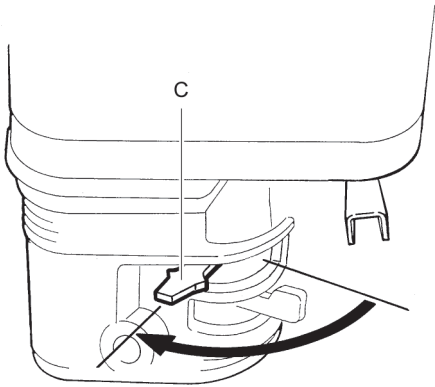

4. Turn the switch (D) to ON.

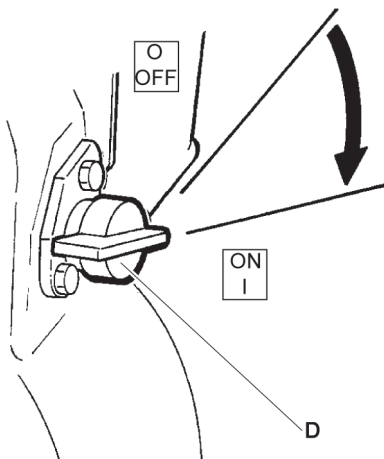

5. Hold the operating handle with one hand and grip the handle of the recoil starter (E) and pull until resistance is felt. Release the handle to the initial position, then pull until the engine starts.

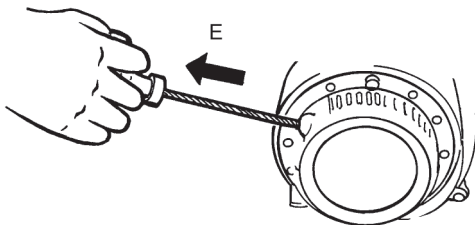

6. Move the choke valve (F) gradually to the fully open position.

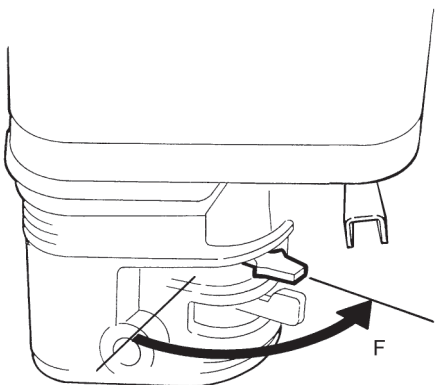

7. Allow the engine to idle a few minutes. Hold the operating handle in a firm grip. Increase

the engine speed with the throttle control (B) on the left side while keeping the operating handle in a firm grip.

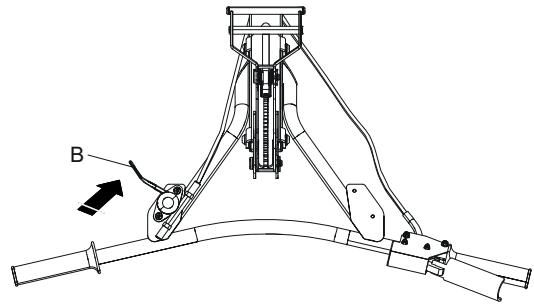

8. Push the clutch handle (G) on the right side until it reaches the operating handle. Keep the clutch handle in this position when operating the machine.

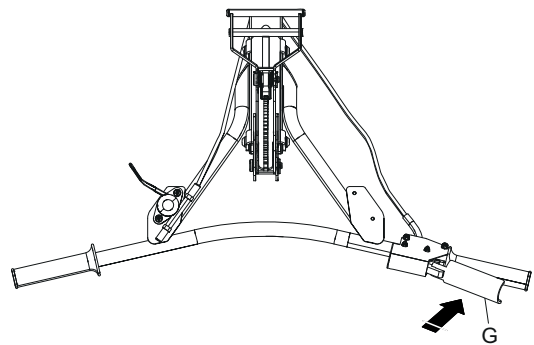

Stopping the engine

1. Release the clutch handle (A) completely. Avoid any slip of the V-belt by releasing it quickly. Let the engine idle for a few minutes.

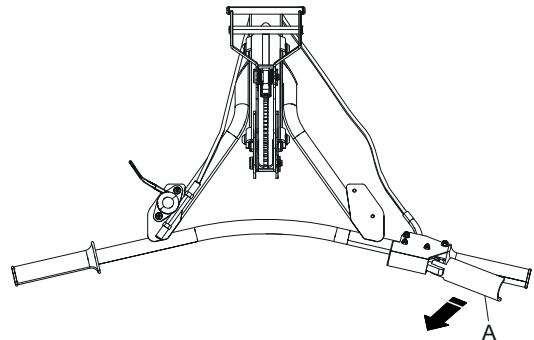

NOTICE It is not advisable to run the engine with the clutch activated except at idle speed. Therefore, reduce the engine speed to idle once the machine has come to a full stop.

2. Turn the switch (B) to OFF.

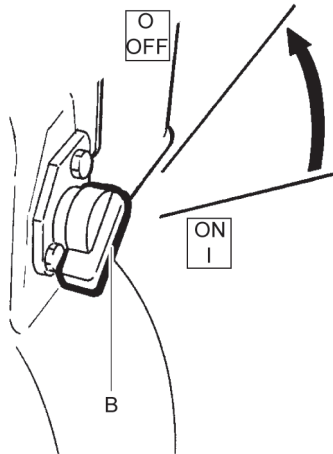

3. Close the fuel cock (C).

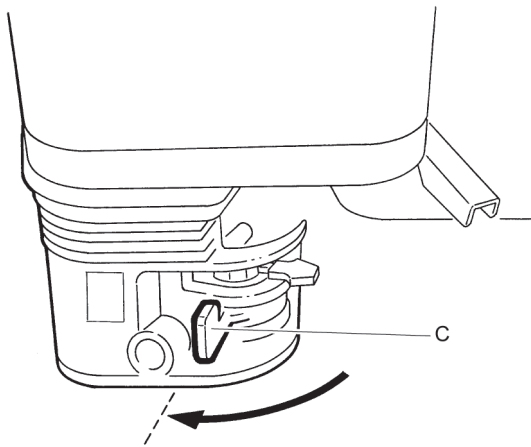

Operating

Floating

When the slab has set sufficiently firm that the operator's footprint leaves a very slight depression on the surface of the slab, it is ready for the floating operation.

Under normal operating conditions the machine should cover as much as 1000 sq. ft. in about 15 minutes. It is recommended that a slight tension on the trowel control cable (but not a definite tilt), during the floating operation will cause the machine to operate much smoother. After the floated slab has set sufficiently, it is ready for the finishing operation.

NOTICE Do not let the machine stand in one spot on the soft cement. Lift from the slab when the floating operation is complete.

Finishing

When starting the finishing operation, never set the trowels up over 1/4" pitch. Best results are obtained by letting the machine move right or left, backwards or forwards, approximately 4" with each revolution of the trowels. To fill a hole or cut down a hump, move the unit back and forth over the problem area.

After the first pass over the slab, the waiting time between operations is determined in the same manner as if you were hand troweling. The entire application and action of the troweling machine in regard to getting on the slab, and the correct pitch of the trowels, is determined in the same manner as would be used by a cement finisher when troweling by hand.

NOTICE When using the floating disc, be aware of the position of the blades. All four blades must be inside the brackets on the floating disc. Also check the centre position of the floating disc in relation to the blade cross, to avoid any eccentricity during rotation.

NOTICE Observe the concrete surface for loosened stones during operation. A stone can make marks on the surface. If this appears during the end of the operation, when the concrete surface is hard and close to be finished, the damage can be hard to restore.

Manoeuvring the trowel

The trowel is manoeuvred by applying force on the handle in different directions. The procedure below describes how to move the trowel in different directions, but just as important is the balance and smoothness of the operator to achieve smooth and easy movements of the machine.

◆ **Turn to the left:**

Lift the handle to turn the trowel to the left.

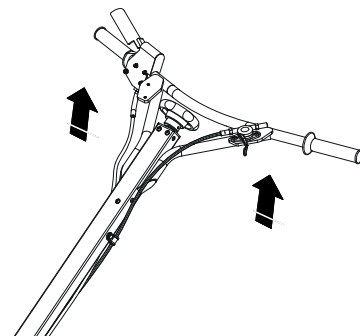

◆ **Turn to the right:**

Press down the handle to turn the trowel to the right.

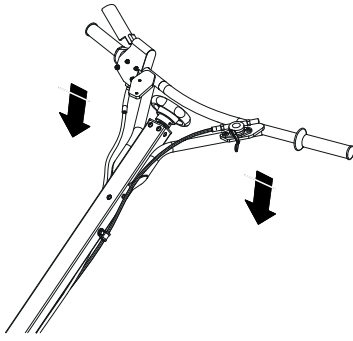

◆ **Move forward:**

Press down the right side of the handle and lift the left side of the handle in one movement to move the trowel forward. This movement can also be achieved by pushing the handle forward.

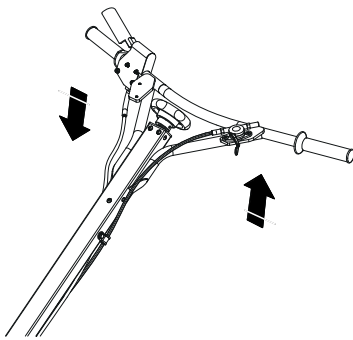

◆ **Move backward:**

Press down the left side of the handle and lift the right side of the handle in one movement to move the trowel backward. This movement can also be achieved by pulling the handle backward.

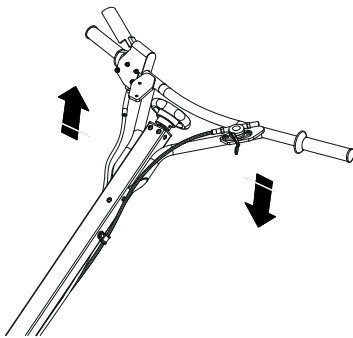

Adjusting the blade angle

Twist pitch

The TP models are equipped with a twist pitch knob for stepless adjusting of the blade angle.

- ◆ To increase the blade angle, turn the twist pitch knob clockwise.

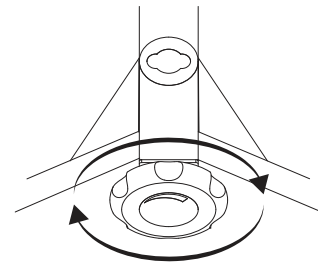

- ◆ To decrease the blade angle, turn the twist pitch knob counterclockwise.

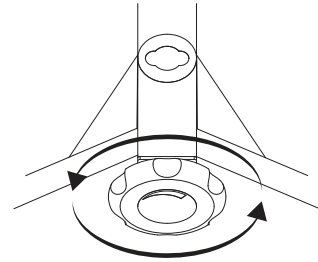

Quick pitch

The QP models are equipped with a quick pitch lever for adjusting of the blade angle.

- ◆ To increase the blade angle, pull the lever backward.

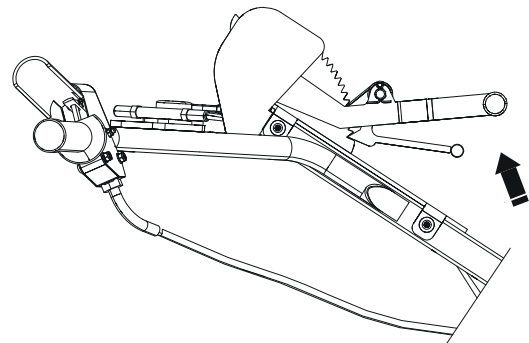

- ◆ To decrease the blade angle, push the lever forward.

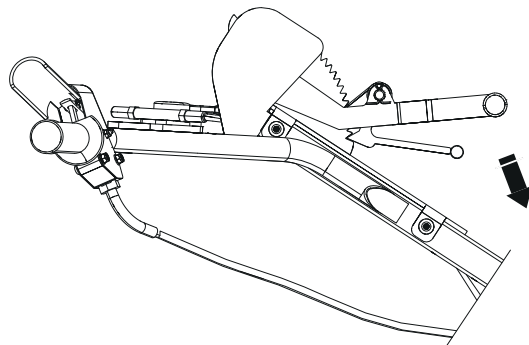

When taking a break

- ◆ Stop the machine during breaks.
- ◆ During all breaks, put the machine away so that there is no risk for unintentional start.

Maintenance

Regular maintenance is a basic requirement for the continued safe and efficient use of the machine. Follow the maintenance instructions carefully.

- ◆ Before starting maintenance on the machine, clean it in order to avoid exposure to hazardous substances. See “Dust and fume hazard”.
- ◆ Use only authorised parts. Any damage or malfunction caused by the use of unauthorised parts is not covered by warranty or product liability.
- ◆ When cleaning mechanical parts with solvent, comply with appropriate health and safety regulations and ensure there is satisfactory ventilation.
- ◆ For major service of the machine, contact the nearest authorised workshop.
- ◆ After each service, check that the machine's vibration level is normal. If not, contact the nearest authorised workshop.

NOTICE Never aim a water jet directly at the fuel filler cap. This is particularly important when using a high-pressure cleaner.

The trowel can be leaned forwards and positioned on the front support frame, when service and maintenance is carried out. This position is also for the replacement or removal of the blades or floating disc.

NOTICE Empty the fuel tank before tilting the machine.

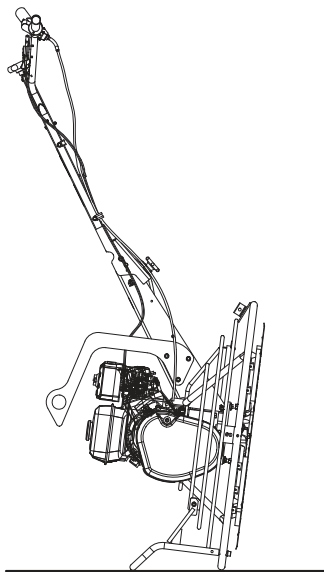

NOTICE Do not tilt the machine in any other direction. Incorrect tilting or leaning can cause problems with engine oil pouring out through the valve into the carburettor.

Every 10 hours of operation (daily)

Maintenance routines:

- ◆ Check and replenish the fuel.
- ◆ Check and replenish engine oil.
- ◆ Check for oil leaks.
- ◆ Clean the air filter.
- ◆ Check the tightness of all nuts and bolts.
- ◆ Clean the machine. After every working shift concrete splashes must be removed from the surfaces when it is still fresh, use high-pressure water.
- ◆ Check and clean the engine's cooling flanges. See the engine manual for more information.
- ◆ Check that the controls are not damaged and do not jam.
- ◆ Check all the wires for wear and correct adjustment.
- ◆ Lubricate the blade shafts.

Checking the engine

- ◆ Check the oil level on the dipstick.

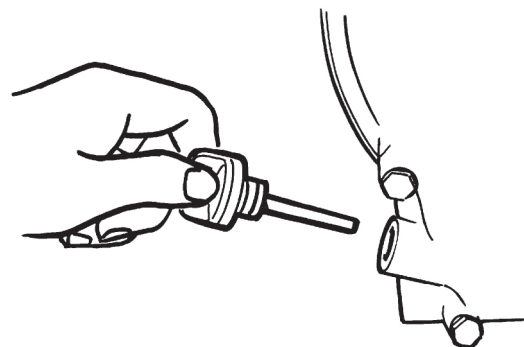

- ◆ Check the fuel level (A).

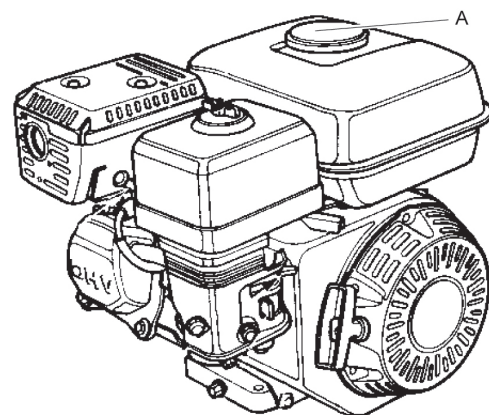

- ◆ Check the engine for oil leaks.
- ◆ Clean and replace the air filter (B) if necessary.

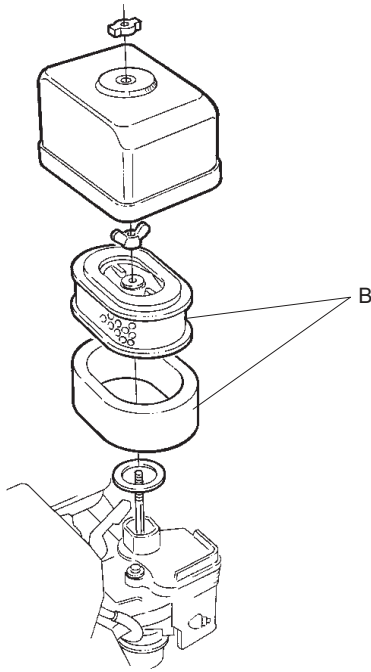

After the first 20 hours of operation

Maintenance routines:

- ◆ Change engine oil.
- ◆ Clean the air filter.
- ◆ Check the engine speed.
- ◆ Lubricate the blade shafts using the grease nipples placed on the hub.

Changing the engine oil

1. Unscrew the drainage plug (A).

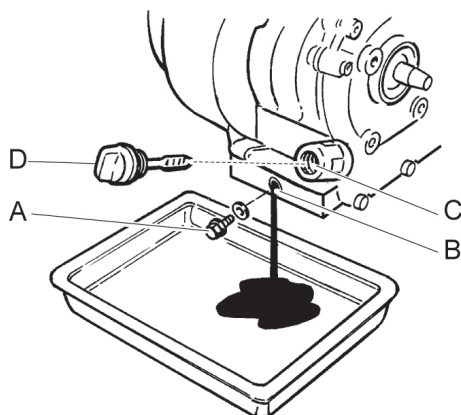

2. Tilt the machine backwards and let the oil drain in a drainage hose.
3. Clean around the hole (B) where the drainage plug (A) was placed.
4. Refit the drainage plug (A).
5. Unscrew the dipstick (D).

6. Fill with oil (C).
7. Refit the dipstick (D).
8. Start the engine and allow the engine to idle a few minutes before increasing to full power.

Every 200 hours of operation (or monthly)

Maintenance routines:

- ◆ Check the engine speed.
- ◆ Check that the V-belt is not damaged.
- ◆ Change engine oil. See engine manual for more information.
- ◆ Check and clean the spark plug. See engine manual for more information.
- ◆ Clean the carburettor's fuel cock. See engine manual for more information.
- ◆ Clean the silencer's spark catcher. See engine manual for more information.

▲ CAUTION Cover the V-belt

Running a machine without the protective cover over the V-belt may cause trapping or machine damage, which can cause injury.

- ▶ Never run the machine without the protective cover over the V-belt.
- ▶ Stop the engine before removing the protective cover.

Checking the V-belt

A correctly tensioned V-belt increases the life of the V-belt and provides the best operating comfort.

1. Remove the protective cover (A) by unscrewing the two screws (B).

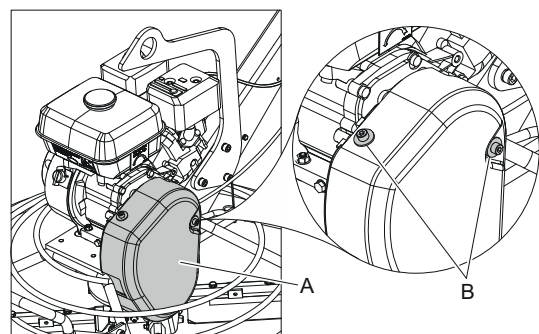

2. Check if the V-belt (C) is damaged, replace if necessary.
3. Check if the belt is correctly tensioned.
4. If the belt is not correctly tensioned, adjust the clutch wire (D) using the conduit nuts (E).
5. Check the position of the V-belt in relation to the pins (F). When the clutch handle is pressed

down there must be a distance of 1-3 mm (0.04-0.12 in.) between the pins and the belt.

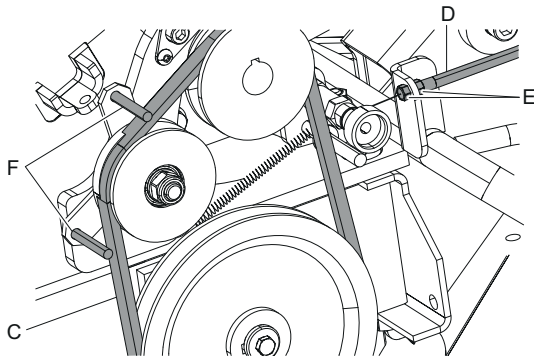

6. Check clutch functionality. When the clutch handle is released with the engine running, the handle pole should be still (no handle pole rotation permitted).
7. If the clutch does not function and the handle rotates, stop the machine and contact the nearest authorised workshop.

Checking spark plug

- ◆ Check, clean and replace the spark plug.

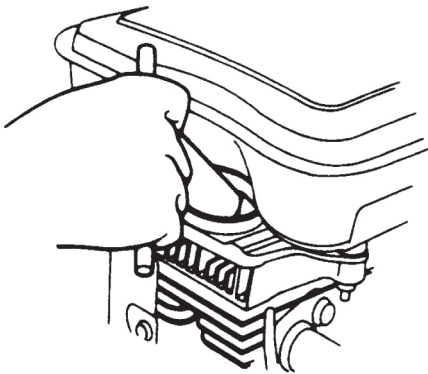

Every 500 hours of operation (or yearly)

Maintenance routines:

- ◆ Adjust valve clearance for intake and exhaust valves. See engine manual for more information.
- ◆ Clean and check fuel filter and fuel tank. See engine manual for more information.
- ◆ Replace air filter.
- ◆ Clean the engine's cooling flanges. See engine manual for more information.
- ◆ Change oil in the engine. See engine manual for more information.
- ◆ Clean and adjust the carburettor. See engine manual for more information.

Cleaning the fuel tank

- ◆ Inspect and clean the fuel tank (A).

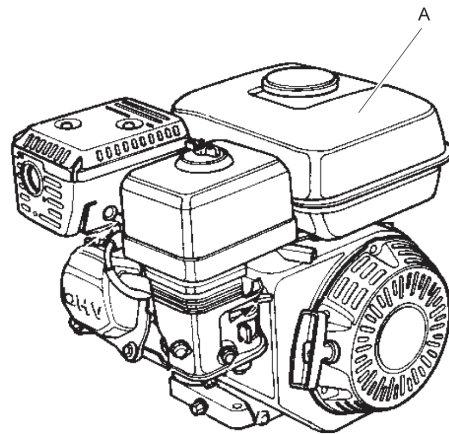

Inspection and adjustment of engine

1. Clean and adjust the carburettor (A).

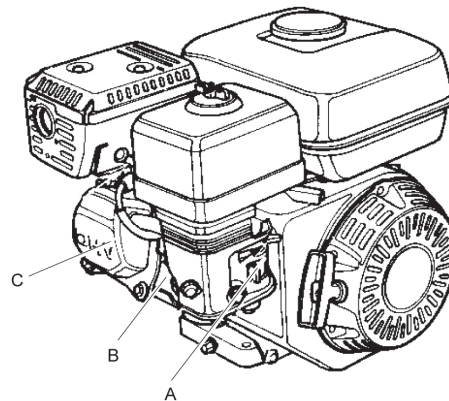

2. Clean engine cooling flanges (B).
3. Adjust the engine's valve (C) clearance.

Cleaning the blade shafts - STG 244

Disassemble the blade shafts from the hub and clean the parts carefully. Grease the contact areas before assembling it again.

1. Remove the screws (A) for the outer ring from the blade shafts (B).

2. Remove the outer ring (C).
3. Pull out the blade shaft (B) from the hub.
4. Clean the contact surfaces on the blade shafts (B) and the hub.
5. Grease the surfaces and reattach the blade shaft (B) again.
6. Finish the procedure by greasing the nipple (D) until grease is coming out from around the blade shafts.

Cleaning the blade shafts - STG 375/479

Disassemble the blade shafts from the hub and clean the parts carefully. Grease the contact areas before assembling it again.

1. Remove the screw (A) and washer (B) to separate the blade shaft assembly from the machine.

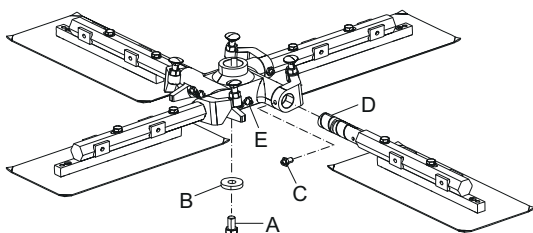

2. Remove the screw (C).
3. Pull out the blade shaft (D) from the hub.
4. Clean the contact surfaces on the blade shaft and the hub.
5. Grease the surfaces and reattach the blade shaft (D) again.
6. Finish the procedure by greasing the nipple (E) until grease is coming out from the blade shaft end piece.

Cleaning the pressure plate

Check the status of the lubrication of the bearings. Use the same grease as for the shafts.

1. Loosen and remove the screw (A) and the washer (B).

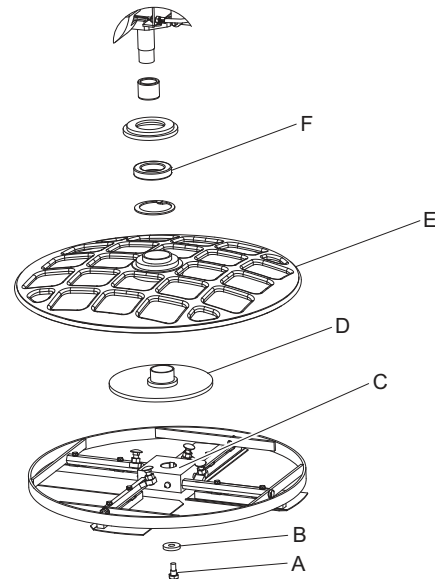

2. Dismount the spider assembly (C). Use a puller if the blade cross is tight on the shaft.
3. Dismount the pressure plate (D), protection ring (E) and the needle bearing (F).
4. Clean the surfaces and grease them carefully.
5. Assemble the parts.

NOTICE The gearbox of the trowel is lubricated for life. If the oil for some reason has to be changed, use recommended oil quality. See section "Technical data".

Repair

Clutch wire replacement

A damaged clutch wire can be replaced using the following sequence.

1. Remove the protective cover (A) by unscrewing the two screws (B).

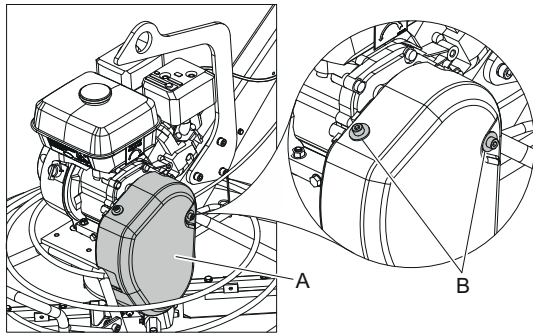

2. Remove the belt (C) from the pulley.
3. Release the spring (G) from the pin (F).
4. Unwind the screw (H).
5. Unscrew the nuts (K).

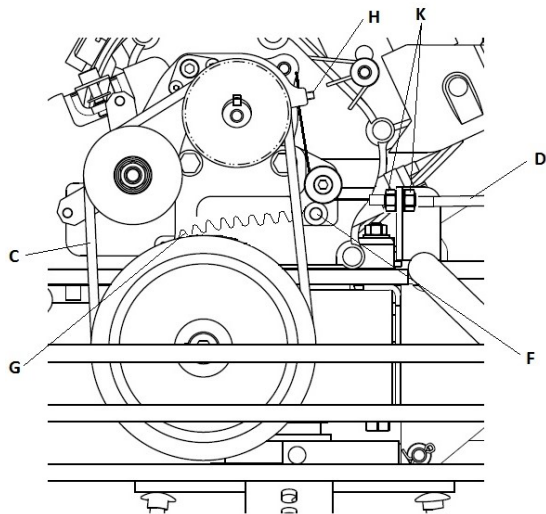

6. Remove the screws (L).
7. Pull out the lever mechanism (M) with attached wire.
8. Drill out the rivet (N).
9. Replace the damaged clutch wire.
10. Install a new rivet (N).
11. Reinstall the lever mechanism (M) with attached wire.
12. Replace the clutch wire conduit, if necessary.
13. Reinstall the screws (L).

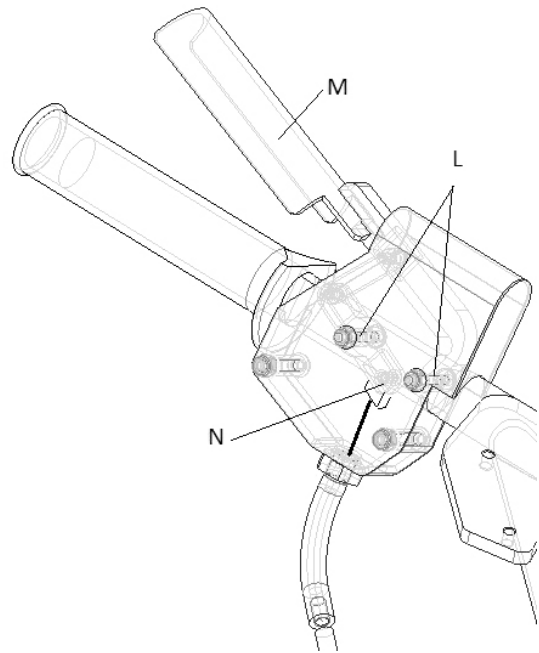

14. Attach the clutch wire conduit to the protective ring by winding the nuts (K).
15. Engage clutch wire by winding the screw (H).
Tightening torque (STG 244/375): 0.55 Nm.
Tightening torque (STG 475): 0.9 Nm.
16. Refit the spring (G).
17. Reinstall the belt (C) and the protective cover (A).
18. Check clutch functionality. See section "Checking the V-belt".

Storage

- Clean the machine properly before storage, in order to avoid hazardous substances. See “Dust and fume hazard”.
- If the machine is stored in the service position, the fuel tank must not be filled more than half full. Otherwise there is a risk that the fuel can come out through the ventilation hole in the fuel tank cap.
- Always store the machine in a dry place.

Disposal

A used machine must be treated and disposed of in such a way that the greatest possible portion of the material can be recycled and any negative influence on the environment is kept as low as possible, and in accordance with local restrictions. Before a fuel driven machine is deposited it must be emptied and cleaned of all oil and fuel. Remaining oil and fuel must be dealt with in a way that does not adversely affect the environment. Always send used filters, drained oil and fuel remnants to environmentally correct disposal.

Troubleshooting

Problem	Cause	Solution
The trowel does not start.	Start switch in off position.	Turn the switch on.
	Fuel cock off.	Open the fuel cock.
	Fuel tank empty.	Fill up the tank.
	Cold engine	Activate the choke.
	Engine faulty.	See engine manual.
The blades do not rotate or rotate too slow, when the clutch handle is activated.	The V-belt is broken.	Replace the V-belt
	The V-belt is slipping or does not tension against the pulleys.	Adjust the tensioning of the clutch wire.
	The clutch wire is broken.	Replace the clutch wire.
The blade cross has difficulty rotating.	Cold engine.	Warm the engine up at idle speed.
	To low r.p.m. when activating the clutch.	Increase r.p.m.
	Floating disc is used and the concrete is too fresh.	Wait until the concrete has dried a little.
	Engine faulty.	See engine manual.
	Gearbox faulty.	Repair or replace the gearbox.
The trowel is shaking.	One or more blades are bent or faulty.	Replace the broken units.
	One or more blades are not moving in the hub.	Disassemble the blades and clean the contact area. Put new grease on all contact areas.
	The pressure plate is askew.	Replace the pressure plate.
The blade adjustment system is out of order.	The clutch wire is broken.	Replace the clutch wire.
	One or more of the blades are not moving in the hub.	Disassemble the blades and clean the contact area. Put new grease on all contact areas.
	The pressure plate is not moving vertically.	Disassemble the blade cross and clean all contact areas.
	The blade adjustment in the operating handle is faulty.	Check all involved parts and replace if necessary.

Technical data

Machine data - STG 244

STG 244 F TP	
Engine	
Manufacture/Type	Honda GX 120, 4-stroke, manual start.
Power, kW (hp)	2.6 (3.5) @ 3.600 rpm
Blade speed, r.p.m.	40-115
Design	
Type of handle	Foldable
Clutch type	Belt clutch
Type of blade angel adjustment	Twist pitch
Type of blade arms	Bolt on
Fluid volumes	
Fuel tank capacity, litres (qts)	2.5 (2.6)
Crankcase oil capacity, litres (qts)	0.6 (0.63)
Gearbox oil capacity, litres (qts)	0.55 (0.58)
Fuel consumption, litres/hour (qts/h)	1.0 (1.06)
Lubricants	
Fuel type	Petrol (gasoline). Use unleaded petrol of standard quality.
Engine oil	SAE 15W/40
Grease, shaft for blade adjustments	Shell Regina Grease 2 or equivalent
Gearbox oil	Synthetic Mobil SHC 634
Weights	
Net weight, kg (lbs)	58 (128)
Operating weight, kg (lbs)	60 (132)

Weights and dimensions for options - STG 244

STG 244	
Floating disc, kg (lbs)	2 (4.4)
Floating disc, mm (in.)	610 (24)
Trowel blades, four units, kg (lbs)	9 (19.8)
Trowel blade, mm (in.)	1140 (44.9)
Protection ring, mm (in.)	1200 (47.2)
Floating blade, mm (in.)	1160 (45.7)

Machine data - STG 375

	STG 375 F TP	STG 375 F QP
Engine		
Manufacture/Type	Honda GX 160, 4-stroke, manual start.	Honda GX 160, 4-stroke, manual start.
Power, kW (hp)	3.6 (4.8) @ 3.600 rpm	3.6 (4.8) @ 3.600 rpm
Blade speed, r.p.m.	40-115	40-115
Design		
Type of handle	Foldable	Foldable
Clutch type	Belt clutch	Belt clutch
Type of blade angel adjustment	Twist pitch	Quick pitch
Type of blade arms	Bolt on	Bolt on
Fluid volumes		
Fuel tank capacity, litres (qts)	3.1 (3.3)	3.1 (3.3)
Crankcase oil capacity, litres (qts)	0.6 (0.63)	0.6 (0.63)
Gearbox oil capacity, litres (qts)	0.55 (0.58)	0.55 (0.58)
Fuel consumption, litres/hour (qts/h)	1.7 (1.8)	1.7 (1.8)
Lubricants		
Fuel type	Petrol (gasoline). Use unleaded petrol of standard quality.	Petrol (gasoline). Use unleaded petrol of standard quality.
Engine oil	SAE 15W/40	SAE 15W/40
Grease, shaft for blade adjustments	Shell Regina Grease 2 or equivalent	Shell Regina Grease 2 or equivalent
Gearbox oil	Synthetic Mobil SHC 634	Synthetic Mobil SHC 634
Weights		
Net weight, kg (lbs)	83 (183)	84 (185)
Operating weight, kg (lbs)	87 (192)	88 (194)

Weights and dimensions for options - STG 375

	STG 375
Floating disc, kg (lbs)	7.2 (15.9)
Floating disc, mm (in.)	940 (37)
Trowel blades, four units, kg (lbs)	9 (19.8)
Trowel blade, mm (in.)	1140 (44.9)
Protection ring, mm (in.)	1200 (47.2)
Floating blade, mm (in.)	1160 (45.7)

Machine data - STG 479

	STG 479 F TP	STG 479 F QP
Engine		
Manufacture/Type	Honda GX 270, 4-stroke, manual start.	Honda GX 270, 4-stroke, manual start.
Power, kW (hp)	6.3 (8.4) @ 3.600 rpm	6.3 (8.4) @ 3.600 rpm
Blade speed, r.p.m.	40-115	40-115
Design		
Type of handle	Foldable	Foldable
Clutch type	Belt clutch	Belt clutch
Type of blade angel adjustment	Twist pitch	Quick pitch
Type of blade arms	Bolt on	Bolt on
Fluid volumes		
Fuel tank capacity, litres (qts)	5.3 (5.6)	5.3 (5.6)
Crankcase oil capacity, litres (qts)	1.1 (1.16)	1.1 (1.16)
Gearbox oil capacity, litres (qts)	0.55 (0.58)	0.55 (0.58)
Fuel consumption, litres/hour (qts/h)	2.4 (2.5)	2.4 (2.5)
Lubricants		
Fuel type	Petrol (gasoline). Use unleaded petrol of standard quality.	Petrol (gasoline). Use unleaded petrol of standard quality.
Engine oil	SAE 15W/40	SAE 15W/40
Grease, shaft for blade adjustments	Shell Regina Grease 2 or equivalent	Shell Regina Grease 2 or equivalent
Gearbox oil	Synthetic Mobil SHC 634	Synthetic Mobil SHC 634
Weights		
Net weight, kg (lbs)	99 (218)	100 (220)
Operating weight, kg (lbs)	103 (227)	104 (229)

Weights and dimensions for options - STG 479

	STG 479
Floating disc, kg (lbs)	-
Floating disc, mm (in.)	-
Trowel blades, four units, kg (lbs)	9 (19.8)
Trowel blade, mm (in.)	1140 (44.9)
Protection ring, mm (in.)	1200 (47.2)
Floating blade, mm (in.)	1160 (45.7)

Noise and vibration declaration statement

Guaranteed sound power level **L_w** according to EN ISO 3744 in accordance with directive 2000/14/EC.

Sound pressure level **L_p** according to EN ISO 11201, EN 500-4.

Vibration value determined according to EN 500-4. See table "Noise and vibration data" for the values etc.

These declared values were obtained by laboratory type testing in accordance with the stated directive or standards and are suitable for comparison with the declared values of other machines tested in accordance with the same directive or standards. These declared values are not suitable for use in risk assessments and values measured in individual work places may be higher. The actual exposure values and risk of harm experienced by an individual user are unique and depend upon the way the user works, in what material the machine is used, as well as upon the exposure time and the physical condition of the user, and the condition of the machine.

We, Construction Tools EOOD, cannot be held liable for the consequences of using the declared values, instead of values reflecting the actual exposure, in an individual risk assessment in a work place situation over which we have no control.

This machine may cause hand-arm vibration syndrome if its use is not adequately managed. An EU guide to managing hand-arm vibration can be found at <http://www.humanvibration.com/humanvibration/EU/VIBGUIDE.html>

We recommend a programme of health surveillance to detect early symptoms which may relate to vibration exposure, so that management procedures can be modified to help prevent future impairment.

Noise and vibration data

	Noise			Vibration	
	Declared values			Declared values	
	Sound pressure	Sound power		Three axes values	
	ISO 11201	2000/14/EC		ISO 20643	
Type	L _p at operator's ear	L _w guaranteed dB(A) rel 1pW	L _w measured dB(A) rel 1pW	m/s ² value	permitted working hours/day
STG 244	85	98	95	3.0	13,2
STG 375	85	100	97	3.9	10,3
STG 479	84	99	97	6.2	6,4

Permitted working hours per day are calculated on action value of 5 m/s² as per 2002/44/EC.

Uncertainties, sound value

Type	Uncertainties, sound value	
	K _{wA} dB(A)	K _{pA} dB(A)
STG 244	2.5	2.5
STG 375	2.5	2.5
STG 479	2.5	2.5

Uncertainty factor for concrete.

Dimensions

STG 244

mm (in.)

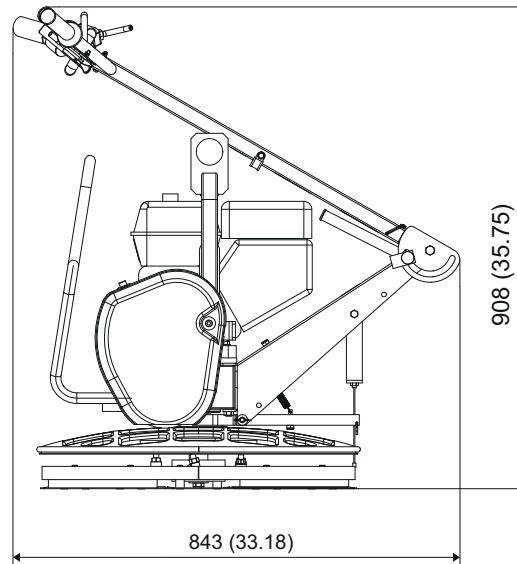
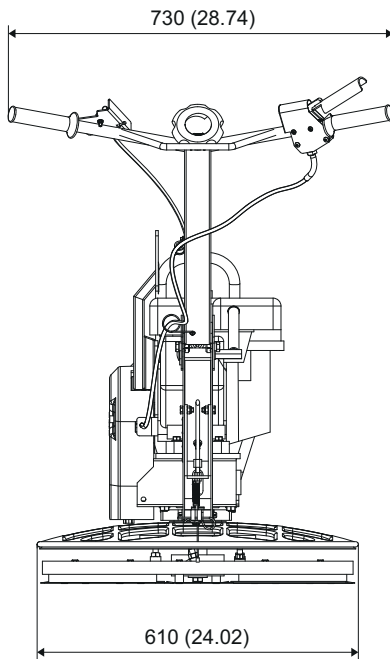
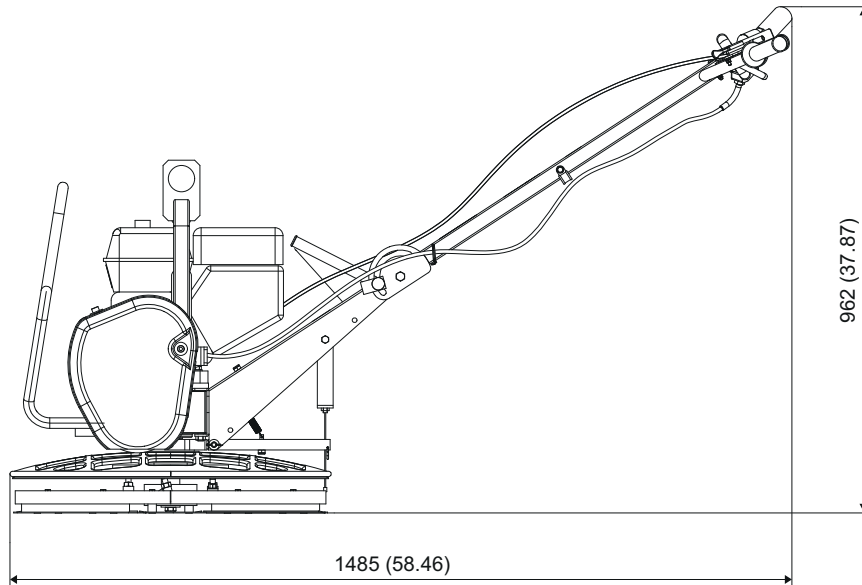

STG 375

mm (in.)

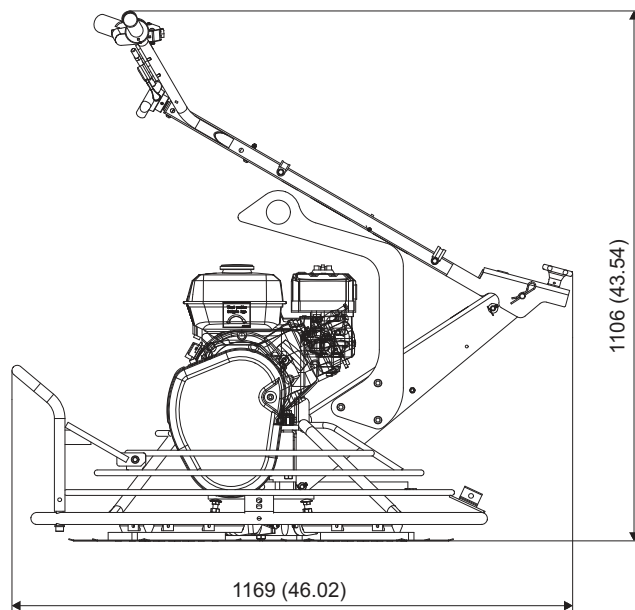
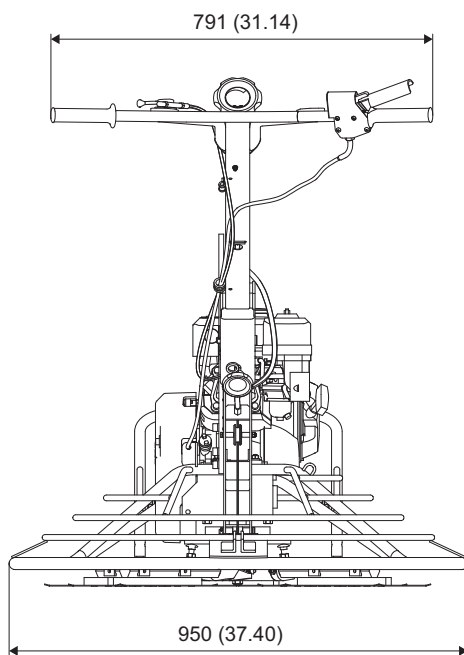
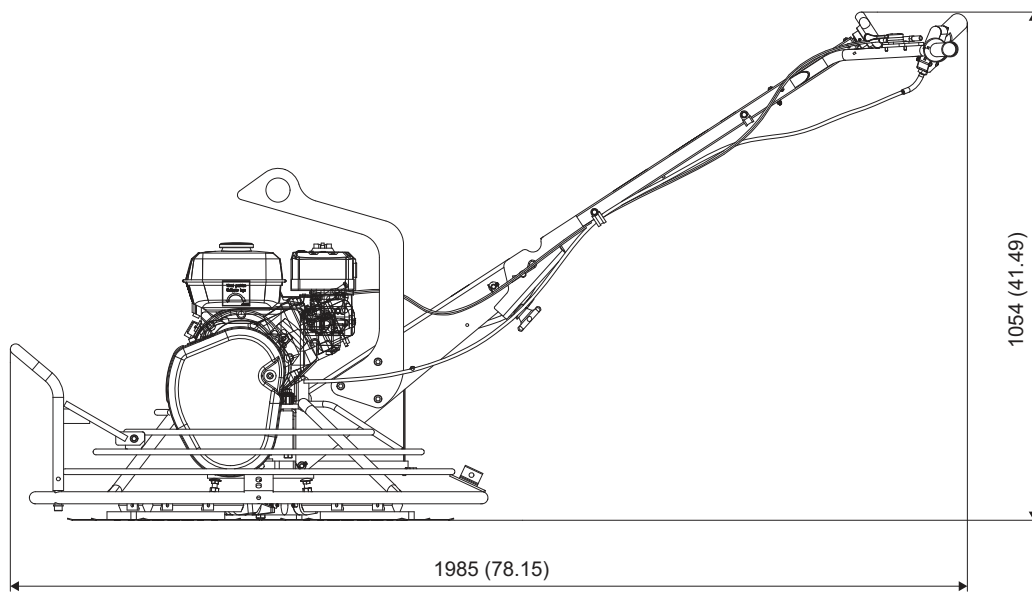

STG 479

mm (in.)

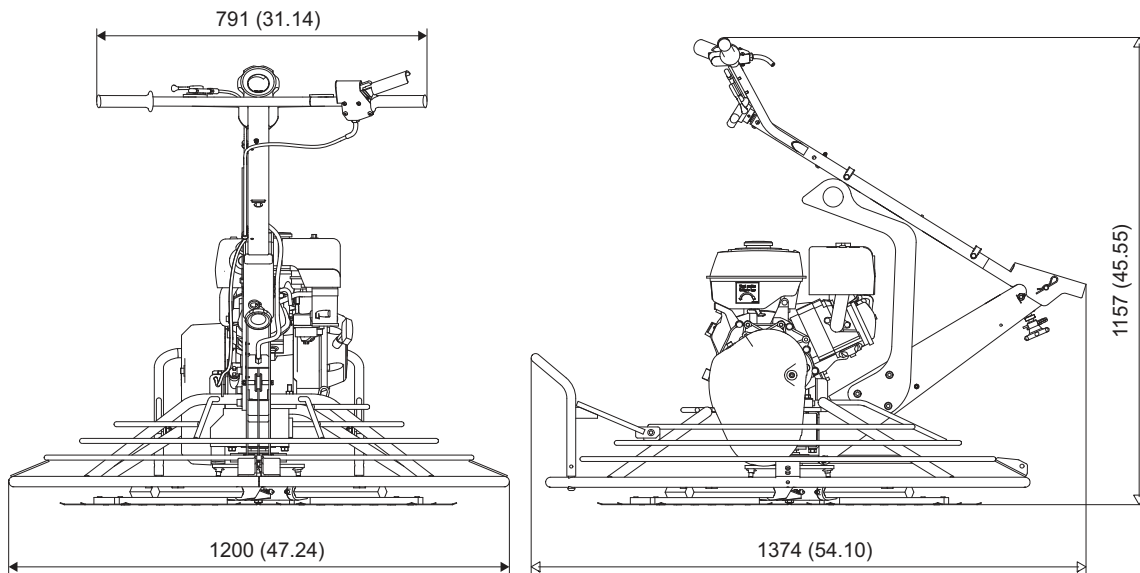
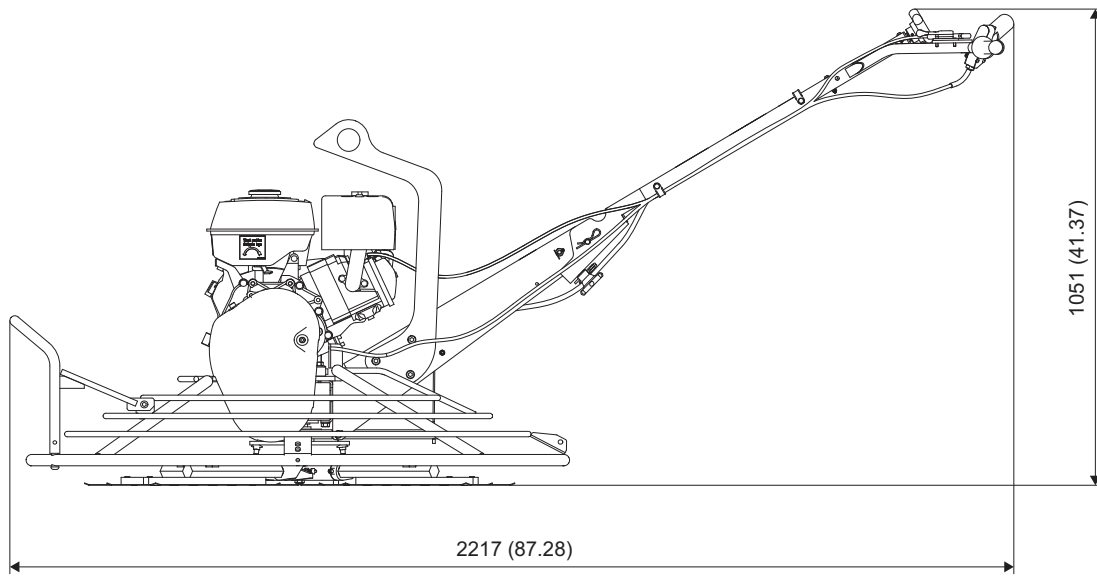

EC Declaration of Conformity

EC Declaration of Conformity (EC Directive 2006/42/EC)

We, Construction Tools EOOD, hereby declare that the machines listed below conform to the provisions of EC Directive 2006/42/EC (Machinery Directive) and 2000/14/EC (Noise Directive), and the harmonised standards mentioned below.

Trowel	Guaranteed sound power level [dB(A)]	Measured sound power level [dB(A)]
STG 244	98	95
STG 375	100	97
STG 479	99	97

Following harmonised standards were applied:

- ◆ EN ISO 12649

Following other standards were applied:

- ◆ 2000/14/EC, appendix VIII
- ◆ ISO 11201
- ◆ ISO 5349-2:2001

Notified body involved for directive:

NoBo no.0038
Lloyd's Register Verification Limited
71 Fenchurch Street
London EC3M 4BS
United Kingdom

Technical Documentation authorised representative:

Emil Alexandrov
Construction Tools EOOD
7000 Rousse
Bulgaria

General Manager:

Stijn Verherstraeten

Manufacturer:

Construction Tools EOOD
7000 Rousse
Bulgaria

Place and date:

Rousse, 2017-08-25



**Chicago
Pneumatic**

2017-08-25 | No. 9800 1838 01

© Construction Tools EOOD